

Screw Pumps & Systems
for Oil & Gas Production

More Efficiency and Sustainability



PUMP TECHNOLOGY

Leistritz Pumpen GmbH, with its headquarters in Nuremberg/Germany, has been producing screw pumps since 1924. The first Leistritz screw pump was developed by Paul Leistritz as main lube oil pump for bearings of steam turbine generator sets.

Now, nearly one century later, Leistritz offers the widest product range of screw pumps world-wide, and has become a reliable supplier and partner for complete plant engineering with an extended scope of supply.

Especially in times of unpredictable oil price fluctuations, the oil & gas industry is experiencing a boisterous development. Innovative pumping systems contribute to flexible, smooth and cost-efficient operations. They are the cornerstones of an economic oil production and handling.

Permanent improvement and development of latest technology in combination with strictly controlled quality is the basis for the globally recognized efficiency and reliability of Leistritz screw pumps.

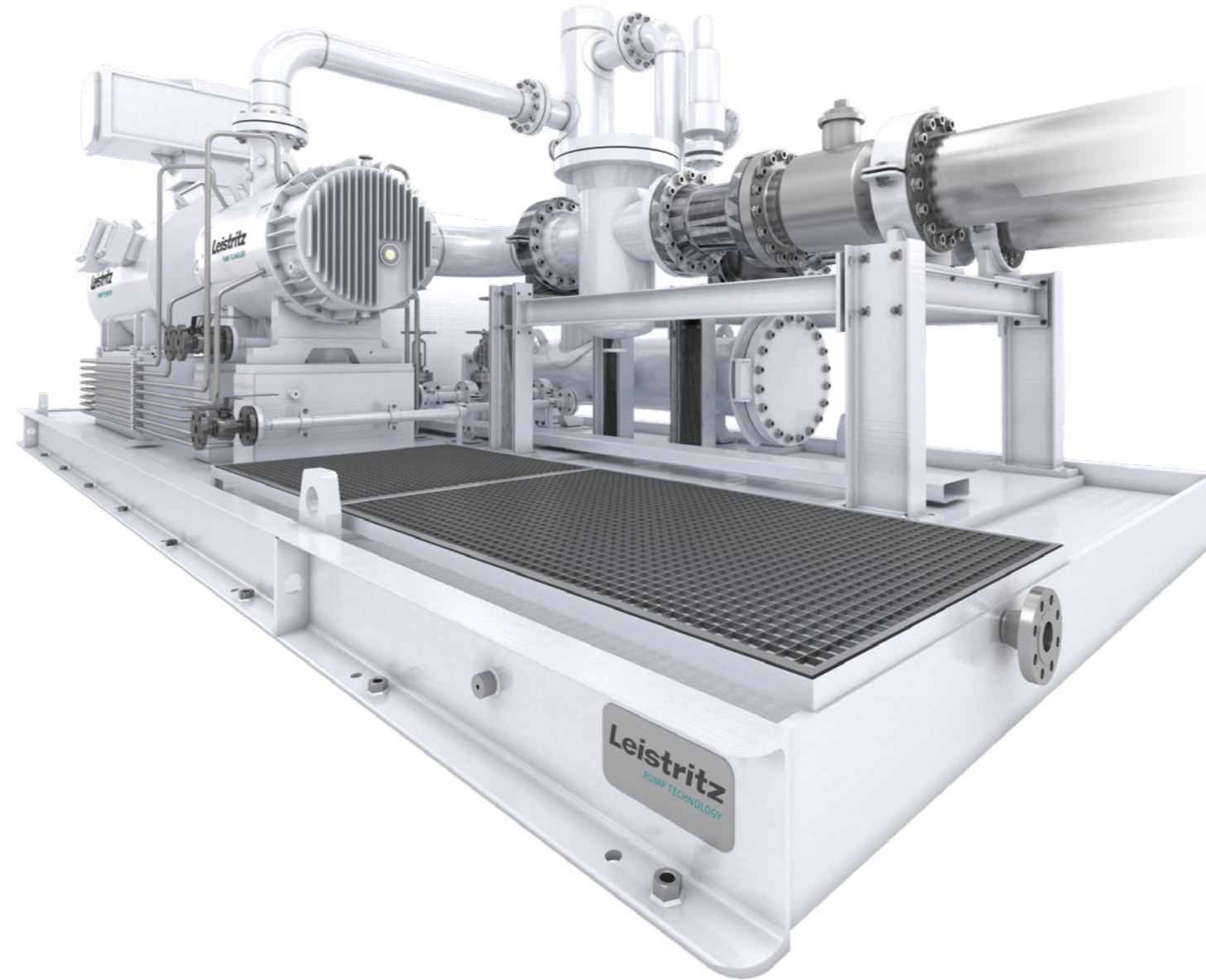

MULTIPHASE PUMPS IN ALGERIA
Leistritz pumps are used in numerous projects all over the world. A recent project in this range was executed in an oil field in Algeria.

Seven Leistritz multiphase pumps have been transferring crude oil and gas with a gas volume fraction (GVF) up to 97 per cent from the wellheads and manifolds to centralised treatment facilities. After separating oil and gas, the oil is transferred over a distance of 700 km across the Sahara to the Mediterranean Sea.

With the multiphase pump as the heart of the system, the scope of supply includes baseframe, driver, instrumentation, on-skid piping with valves, auxiliary systems, control equipment etc..

THE OIL & GAS INDUSTRY

The oil & gas industry is divided into three major sectors, up-, mid- and downstream. Exploration operations are usually simply included in the upstream category. Screw pumps are globally used in the oil & gas industry for handling crude oil, emulsions, produced water, multiphase fluids with high gas contents as well as intermediate and final liquid products. Based on the largest product range of twin, triple and even five screw pumps world-wide, Leistritz offers detailed and customized solutions for nearly all kinds of applications in the oil & gas industry.

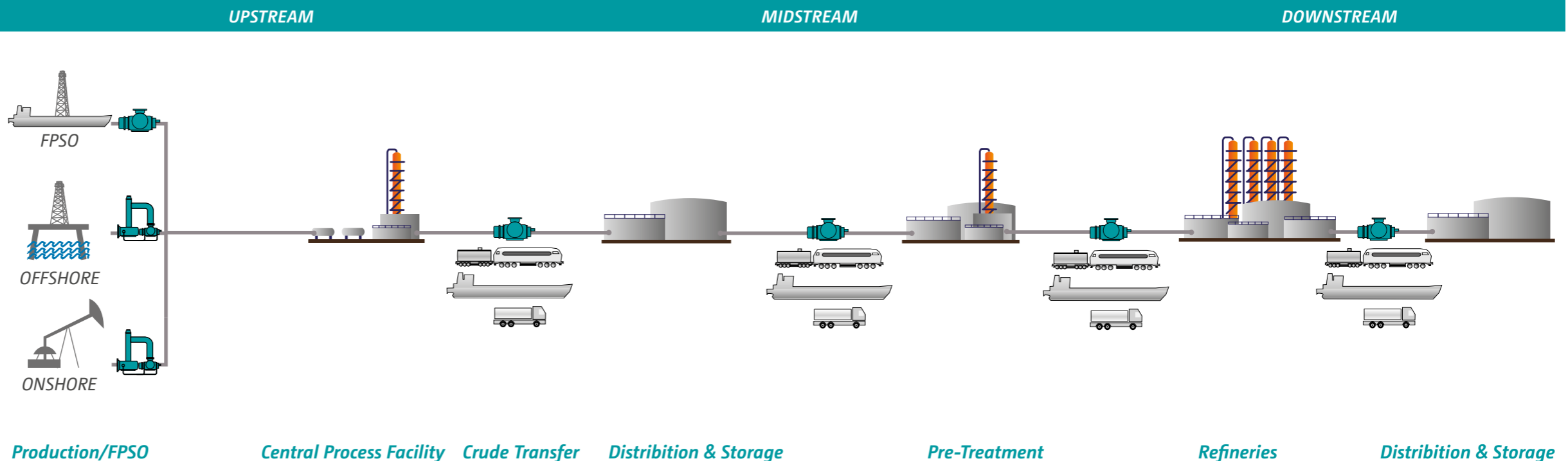



PRODUCTION

Handling liquids and gas at the wellhead of an oil field is a costly procedure.

Using multiphase pump technology facilitates a wide range of benefits such as flexibility of production and distinctly reduced capital- as well as operational expenses.

The conventional way is to separate the associated gas from the liquid fraction and to convey them in separate pipelines to a gathering point for the next handling process.

Extensive conventional equipment like separators, compressors, liquid pumps, heaters or individual flow lines are now replaced by economical multiphase pumps, which boost the entire well flow to a central treatment facility through only one pipeline.

Leistritz multiphase pumps and systems are globally used for handling untreated well flow with gas volume fractions (GVF) up to 100 %, flow rates up to 5000 m³/h and differential pressures up to 100 bar.

Our pump systems are designed to operate under severe ambient conditions in remote locations onshore, offshore or even subsea.

With our expert knowledge far beyond the pump, Leistritz can provide an extended scope of supply including process piping and instrumentation as well as complete electrical equipment and engineering support.



MULTIPHASE BOOSTER PUMP L4MK

The untreated well flow is boosted by Leistritz multiphase pumps, series L4, to a central treatment facility. With their ability to work at low suction pressure along with a high differential pressure capability, Leistritz Multiphase Pumps are ideal for applications on marginal and declining oil fields. External liquid management systems guarantee trouble-free operation in case of extended slug flow periods.

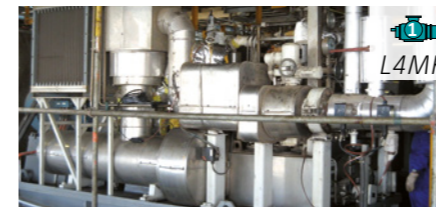

MULTIPHASE PUMP L4 WITH THERMAL INSULATION

Leistritz multiphase pumps with insulation are used for applications where the systems are installed outside under severe ambient conditions. The insulation of the pumps, the piping and the instrumentation along with heat tracing ensures trouble-free operation in case of sudden frost or low temperature periods during the winter months.



MULTIPHASE PUMP L4 ON OFFSHORE PLATFORMS

Based on their small footprint and low weight, Leistritz multiphase pump systems are particularly suitable for the installation on offshore platforms. The skid design and the arrangement of the accessories can be adapted to the available space on large production platforms or small wellhead platforms.



MULTIPHASE PUMP L4 AS MOBILE BLOW DOWN UNIT

Leistritz multiphase blow down units are portable, self-contained pump units to remove and boost liquids when gas wells stop flowing due to unwanted liquid plugs. This eliminates the need of flaring or venting and allows the operator to capture all the valuable gas and NGLs in their existing pipeline network.

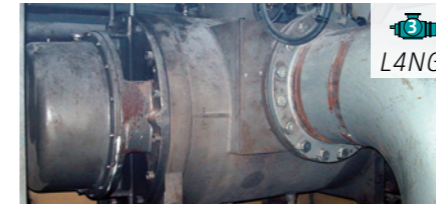

PRODUCED WATER PUMP L4

Formation water or injected water are usually produced along with oil and gas from a well or well cluster. The so called produced water is separated and treated to minimize the final oil and solids content. Leistritz L4 Pumps are used to re-inject the produced water into the reservoirs to force the oil to the surface.

CONVENTIONAL SYSTEM

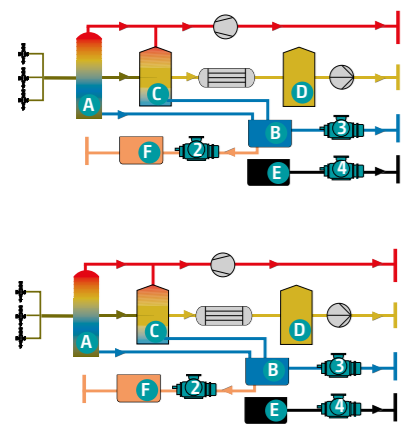

MULTIPHASE SYSTEM (MPP)

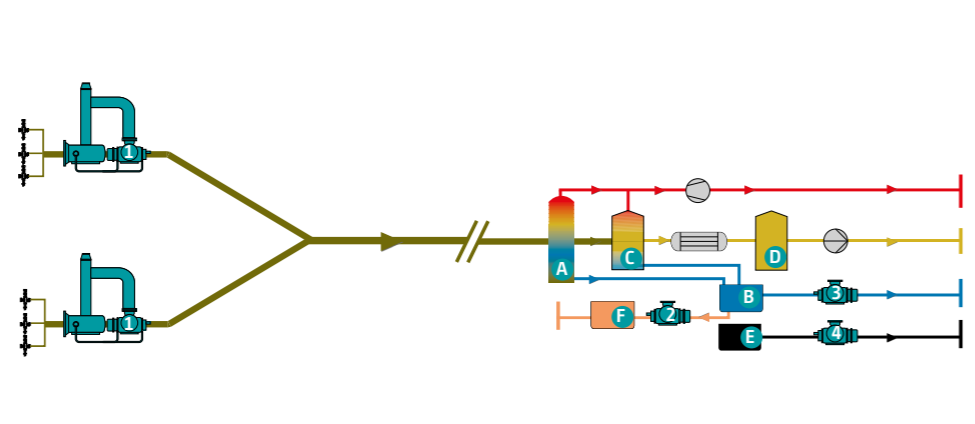

- Well flow (multiphase)
- Crude oil
- Gas
- Water
- Chemicals
- Slops & drains
- ▬ Heater/treater
- ⊖ Export oil pump
- ⊖ Gas compressor
- ① Multiphase pump
- ② Chemicals handling pump
- ③ Produced water pump
- ④ Slops & drains pump
- Ⓐ Production separator
- Ⓑ Water treatment
- Ⓒ Wash tank
- Ⓓ Crude oil storage
- Ⓔ Slops & drains tank
- Ⓕ Chemical storage tank



» Leistritz multiphase pumps are controlled with variable speed drives to react immediately on changing process conditions without the need of system modification and/or reinstallation. «

ADVANTAGES LEISTRITZ MULTIPHASE PUMP SYSTEM:

- Reduction of CAPEX and OPEX by eliminating separation and processing equipment
- Proper well management to increase production efficiency
- Reducing the back pressure on the well allows the reservoir to accelerate effective production and extend the time of possible well operation
- Limitation of environmental impact by eliminating the need of gas flaring
- Reduction of overall system foot print and weight
- Integration of various low pressure lines into a single high pressure line by pressure boosting
- Flexible and reliable operation



FPSO

The offshore oil & gas industry uses floating production, storage and off-loading (FPSO) vessels in order to process and store gas and oil until it can be unloaded onto tankers or forwarded through pipelines.

The well flow is boosted by single phase or multiphase pumps. Leistriz twin screw pumps of the L4-Series are particularly suitable for this purpose.

The export crude oil is transferred by twin screw pumps (L4-Series) or triple screw pumps (L3-Series). High volume twin screw pumps transfer the crude oil to shuttle tankers which serve refineries and storage terminals onshore.

During oil production not only crude oil and gas is pumped but also produced water which can have a high amount of corrosive contents. For that reason all medium wetted pump parts can be made of special materials in order to prevent pitting corrosion. Leistriz screw pumps are typically used for boosting the produced water into a hydro cyclone where the remaining oil and sand will be extracted.

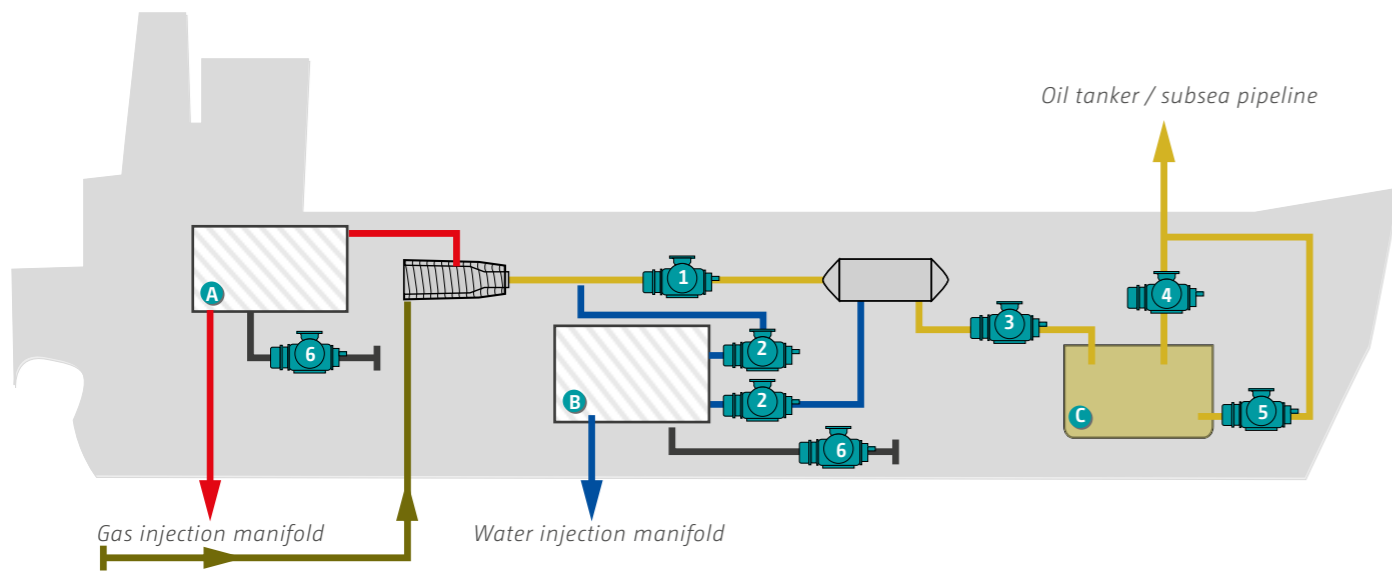

- Well flow
- Oily water
- Crude oil
- (Wet) gas
- Stage separator
- Electric dehydrator
- A Gas compression treatment
- B Produced water system
- C Crude oil tank
- 1 Electric dehydrating pump
- 2 Produced water pump
- 3 Crude forwarding pump
- 4 Crude transfer/unloading pump
- 5 Stripping pump
- 6 Slops and drains pump



ELECTRIC DEHYDRATING PUMP

One method used to separate water from oil in offshore oil fields is the principle of electrostatic separation. Leistriz dehydrating pumps, series L4, are used for the supply of the electrostatic separator. The water content of crude oil is a very important parameter that characterizes the grade or quality. In general a water content (BSW) of 0,2 % to 0,5 % by volume is considered as acceptable. The small water drops in crude oil are getting separated in a strong electric field. Cathods and anods attract small water drops in order to form bigger ones. This procedure enables water separation from crude oil.



PRODUCED WATER BOOSTER PUMP

Formation water or produced water are usually explored along with oil and gas from a well or well cluster. The produced water is separated and treated to minimize the oil and solids content.



CRUDE FORWARDING PUMP

After the electrostatic separation Leistriz triple screw pumps, series L3, are used for transferring oil from the settling tank to the storage tank in the FPSO vessel.



CRUDE TRANSFER/UNLOADING PUMP

Leistriz L4 pumps will transfer the crude oil from the crude oil tank to the oil tanker. Low NPSH requirements and reliable flow, free of turbulence, easy handling and many more are major advantages.



STRIPPING PUMP L4

The product remaining on the bottom of the crude storage tanks is normally of heavy and high viscous nature and contains solids. Low speed Leistriz screw pumps, series L4, with excellent suction capabilities and the ability to run dry are preferred for tank stripping. Variable speed operation along with a special screw design guarantees excellent NPSHR values and minimized pulsation.



SLOPS & DRAINS PUMP

Slop and drain systems are used to collect leakages and drainages from stationary or rotating equipment in upstream production facilities. The systems can be open or closed. In horizontal or vertical position Leistriz L4 pumps are used to transfer these mixtures of water, hydrocarbons and solids to separators or to re-inject into the trunk line.

TYPICAL FPSO ARRANGEMENT

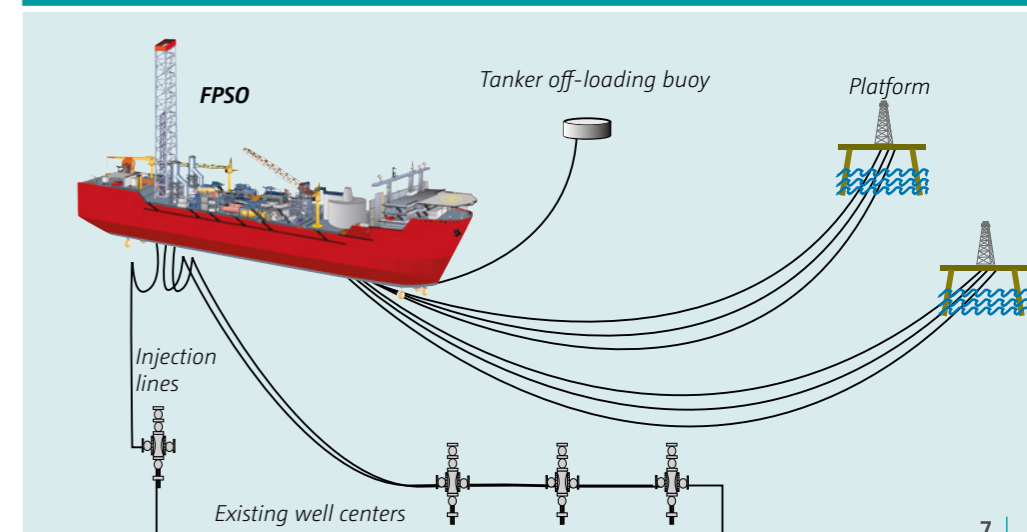



CRUDE TRANSFER

Large amounts of oil and gas products are transferred via pipelines for hundreds of miles. To overcome the pressure demands, with coincident high efficiencies, Leistriz booster pumps are used. To bring a liquid filled pipeline back to operation, it is inevitable to accelerate the liquid flow to a certain level of velocity. The mass inertia of the liquid column and the friction losses of the liquid inside the pipeline system, will cause, depending on the pipeline length, a high back-pressure during start-up of the system. This leads to distinctly increased torque and power requirements through the complete speed range of the pump.

To avoid unnecessary oversized motors and variable frequency drives, smaller start-up pumps are used for getting the pipeline back to normal operation. These pumps are specially designed for high differential pressures with a defined flow rate which is mostly lower than for the main booster pumps.

After the flow velocity is reached, the main pumps are switched into operation for further increase of the flow rate up to normal operation conditions.



BOOSTER PUMP L3 AND L4

Different types of oil can be boosted up to high differential pressures with our Leistriz twin screw or triple screw pumps. The usage of variable speed drives ensures a flexible, economic and reliable run during changing operation conditions and start up.



START-UP PUMPS L3 AND L4

Smaller high pressure triple screw pumps, series L3, or high pressure twin screw pumps, series L4, are installed in bypass as pipeline start-up pumps for a differential pressure up to 100 bar. These pumps are required when the main pipeline pumps cannot overcome the friction losses during start-up of a filled crude oil pipeline. After the fluid is running, it will be switched to the bigger booster pump.



CRUDE TRANSFER PUMPS L2, L3 AND L4

For pumping crude oil through pipelines to a refinery or to ships, railcars or trucks, crude oil transfer pumps are required. Leistriz screw pumps are capable of handling wide viscosity and pressure ranges at flow rates up to 4000 m³/h. Screw pumps, series L4, are typically used as crude oil transfer pumps. L3-series triple screw pumps and L2-series twin screw pumps are used for special transfer applications.

TRANSPORT OF AGGRESSIVE FLUIDS

- To transport fluids with highly abrasive, corrosive and/or hazardous contents you need the flexibility to use different types of material with constant quality and performance.
- Leistriz pump materials are always selected according to client's operating conditions and range from simple carbon steel to superduplex or alloy grades. Additionally Leistriz offers various types of surface treatments such as stellite, tungston carbide or hard-chrome coatings.

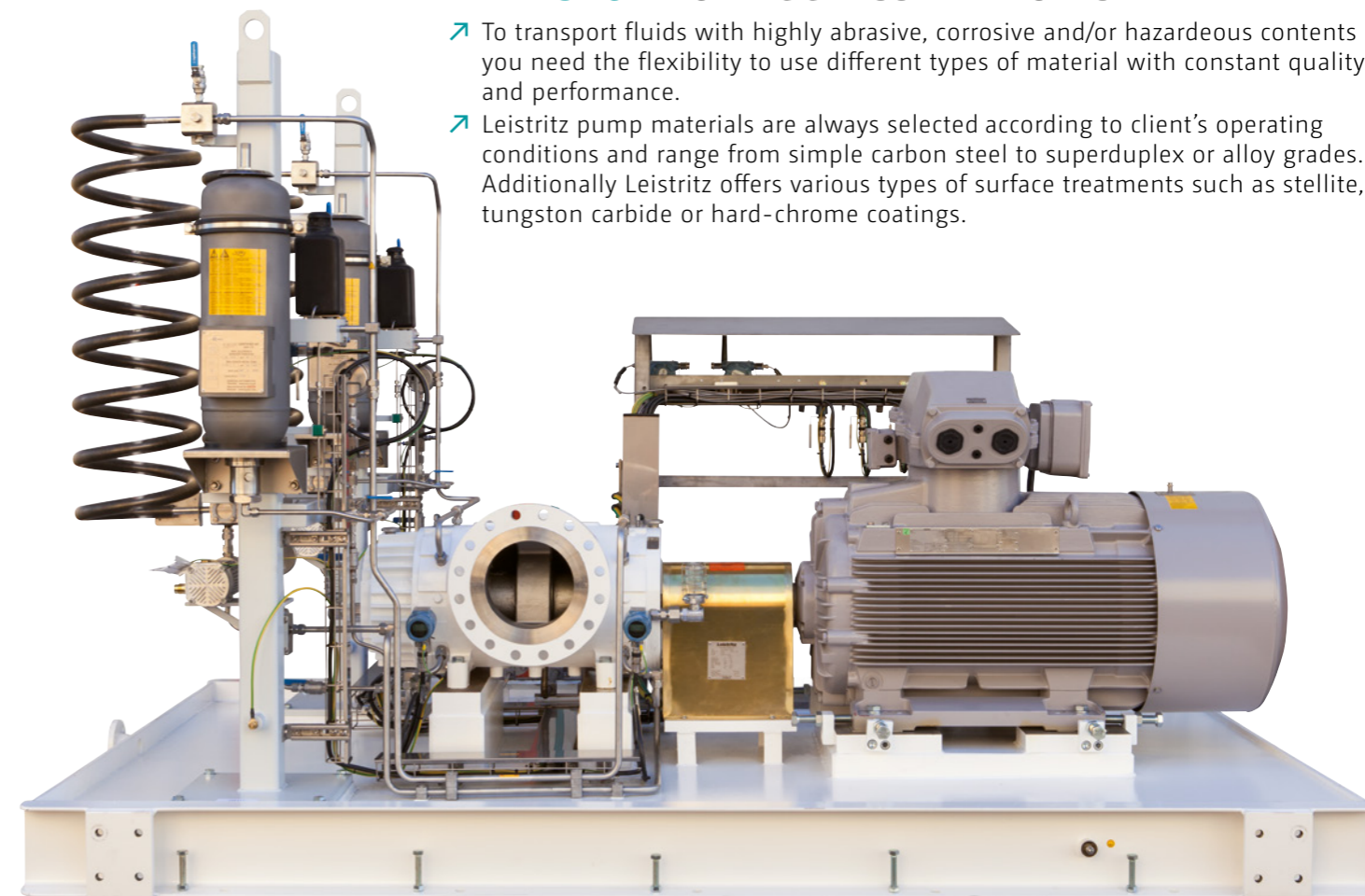

» Leistriz L4 transfer pump made of super duplex stainless steel for a client in the Middle East, specially designed and adapted to its application.«

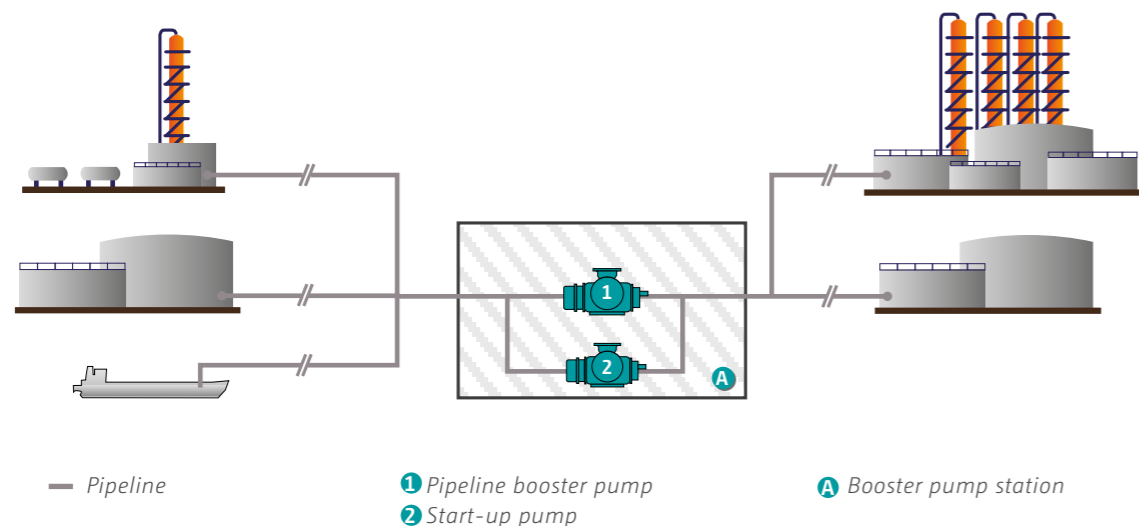



DISTRIBUTION & STORAGE

Midstream and downstream

With the enormous increase of oil production worldwide, efficient above-ground tank concepts at storage terminals became the basis of a reliable and cost efficient mid- and downstream process. Well sized storage reservoirs provide buffers between the production and the treatment of crude oil or respectively between product treatment and end users to allow the timely accurate delivery of its stored products. High energy demand, worldwide tight environmental regulations and the need of operating cost reduction are the main focuses of today's end users. For effective distribution different kinds of fluids need to be handled trouble free at the same time.

Leistritz answers to this demand with reliable pump systems with low MTBFs which can work on lowest NPSH/NPIP margins and which can react on changing operating conditions immediately and without the need of a process shut down.

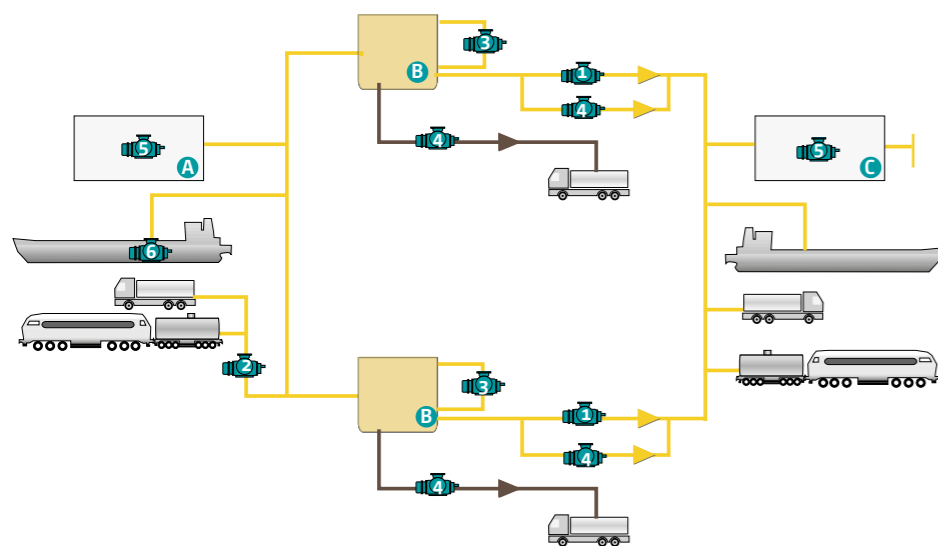

- Crude and refined product
- Residue
- A** Oil field
- B** Booster pump station
- C** Storage tank
- 1** Terminal unloading pump
- 2** Loading and transfer pump
- 3** Circulation/ tank cleaning pump
- 4** Stripping pump
- 5** Pipeline booster pump (page 8/9)
- 6** On-board crude oil cargo pump (page 6/7)

UNLOADING PUMPS L2, L4 AND L5

Unloading of different oils from trucks and railcars are typical applications for Leistritz screw pumps, series L2, L4 and L5. L2- and L5-series pumps have only one sealing to the atmosphere while the L4-Series can offer an interchangeable liner. All of these pumps have the ability to run dry (L2 and L5 with time limitation), they are self priming and can handle a certain amount of solids.



LOADING AND TRANSFER PUMP L2, L3, L4 AND L5

A variety of oil based products are transferred from the storage tanks to ships, railcars and trucks for transportation to the end users. Leistritz screw pumps of all series are used in these applications. Leistritz screw pumps, series L2 and L3, are transferring both, light and heavy oil to different storage facilities and to load trucks and railcars. With their excellent suction capability and low pulsation, L4-pumps are used in these applications for higher flow rates. The pumps handle viscosities of more than 3,000 cSt. A special screw design guarantees very low NPSHR values. Flow rates up to 4,500 m³/h permit short loading periods resulting in low port fees for ocean going vessels. L5-series pumps are also used for high flow rates and pressure up to 10 bar.



CRUDE CIRCULATION PUMPS L2, L3 AND L4

The crude oil stored in the tanks must be circulated to avoid separation and to maintain the temperature. Additionally, the system pipework must be regularly flushed to prevent the adhesion of wax or other substances reducing the nominal diameter. Leistritz screw pumps, series L2, L3 and L4, are used to circulate the product through the system pipework and/or heaters.



RESIDUE/TANK CLEANING PUMP L4

Crude oil storage tanks must be cleaned on a regular basis. Leistritz screw pumps, series L4, handle these often highly viscous residues consisting of heavy oil sludge and solids. Special tungsten carbide coating of the screws and stellite coating on the liners protect the pumps against excessive wear and increase the service life considerably.



STRIPPING PUMP L4

The product remaining on the bottom of the crude storage tanks is normally of heavy and high viscous nature and contains solids. Low speed Leistritz screw pumps, series L4, with excellent suction capabilities and the ability to run dry are preferred for tank stripping. Variable speed operation along with a special screw design guarantees excellent NPSHR values and minimized pulsation.





REFINERY

The unprocessed crude oil has to be refined into consumable petroleum products. These refined products are usually grouped into three categories:

Light distillates (LPG, gasoline, naphtha), **medium distillates** (kerosene, diesel) and **heavy distillates/residues** (fuel oil, lubricating oils, wax, tar).

From unloading the unprocessed crude to loading of the final products, Leistriz screw pumps are operating in various functions in oil refineries.

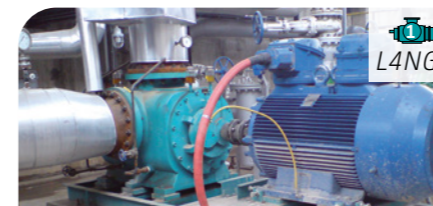

CRUDE UNLOADING AND FINAL PRODUCT LOADING PUMPS L2 AND L4

Various types of crude oil must be unloaded from different sources (like railcars etc.) or pumped from the onshore production site to the refinery. The final products are loaded onto ships, railcars or trucks. For both services Leistriz twin screw pumps, series L2 and L4, are the preferred choice because of their high flow rates and self-priming, dry-running and solids handling capabilities.



CRUDE CHARGING PUMPS L2 AND L4

Leistriz Screw Pumps transfer and charge the crude oil to the various processes of the refinery. All Leistriz screw pump series can be used, however, twin screw pumps of the L2- and L4-series are preferably used because of their ability to handle larger solids in the product, which offers an extended MTBF.



ATMOSPHERIC TANK BOTTOMS /VACUUM RESIDUE PUMP L4

The tank bottoms from the atmospheric distillation vessel must be transported to the vacuum distillation vessel. After distillation the vacuum residues are transferred to the de-asphalting process for the production of asphalt, bitumen, wax and fuel oil. These hot bottoms and residues are usually pumped with Leistriz screw pumps, series L4, which are designed to handle large solids at temperatures up to 320°C. The low NPSHR values of the Leistriz twin screw pumps, series L4, allow a higher reactor vacuum and hence, an improved reactor efficiency.



SLOPS & DRAINS OIL PUMPS L2 AND L4

Various drains and waste hydrocarbons must be pumped to the separator station of a refinery. All Leistriz screw pump series can be used. twin screw pumps of the L2- and L4-series are primarily installed because of their solids handling abilities.



BLENDED/FINAL PRODUCT TRANSFER PUMPS L2 AND L4

The clean or blended refined products are transferred to the export tanks. High viscous liquids as heavy fuel oil, paraffin, wax, asphalt, bitumen, base oil and molten sulphur as well as light products are handled by Leistriz screw pumps of all series. Twin Screw Pumps of the L2- and L4-series are mainly used because they tolerate large solids in the pumped product, which offers an extended MTBF.



CIRCULATION PUMPS L2 AND L4

Particularly high viscous products (e.g. asphalt/bitumen) have to be circulated in the storage tank to guarantee homogeneous product quality in all tank levels. The circulation of these hot, viscous hydrocarbons is usually done by Leistriz twin screw pumps, series L2 and L4.

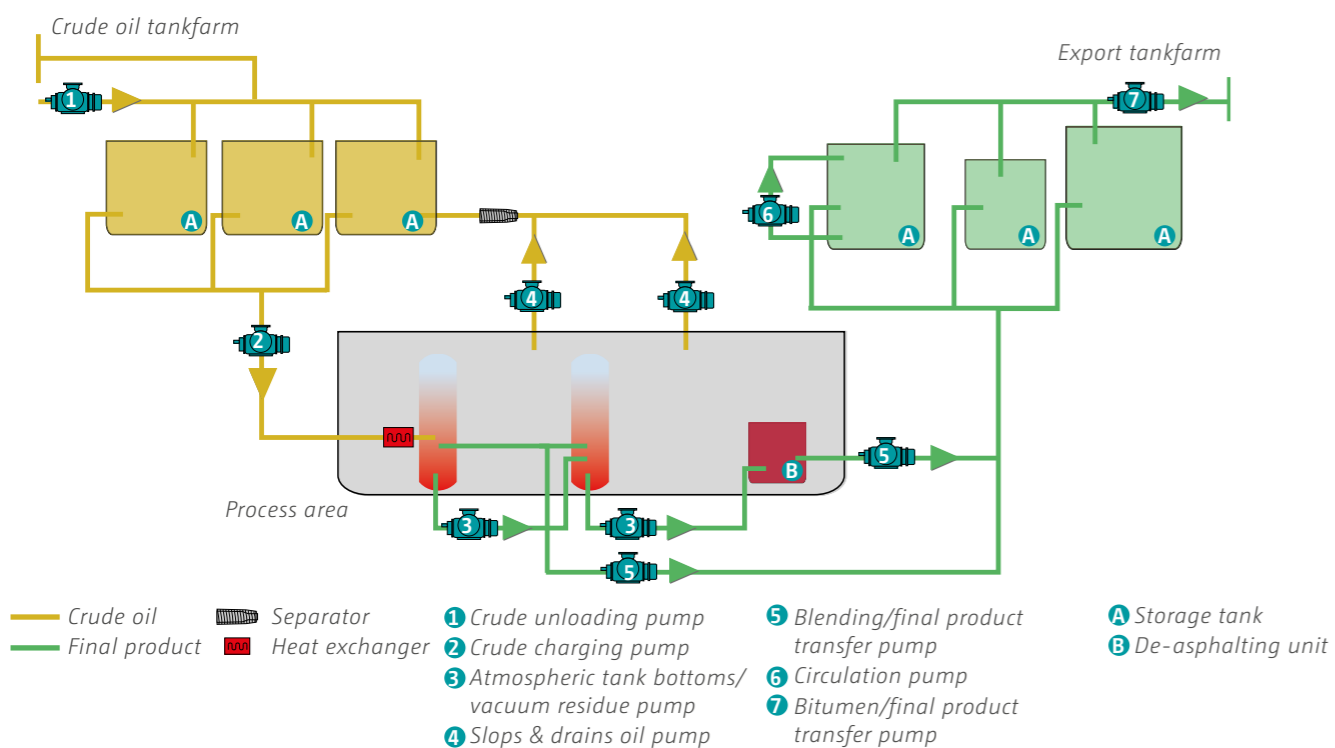

L2NG AS BITUMEN/FINAL PRODUCT TRANSFER PUMP

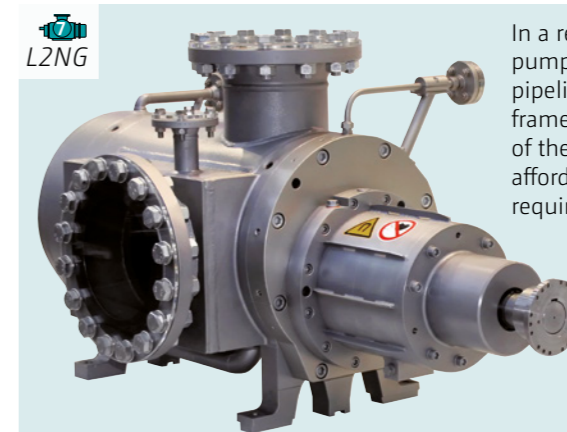

In a refinery, several competitor double floating pumps, were exchanged and the existing pipelines could be used. Only a new base frame and completely new electronics are part of the scope by Leistriz. Now the pump can afford higher flow volumes with a lower power requirement. Other advantages:

- magnetic coupling extremely easy to maintain
- only one seal – compared to 4 shaft seals
- compliant to the German-Clean-Air-Act
- less spare parts

L4 MODULAR

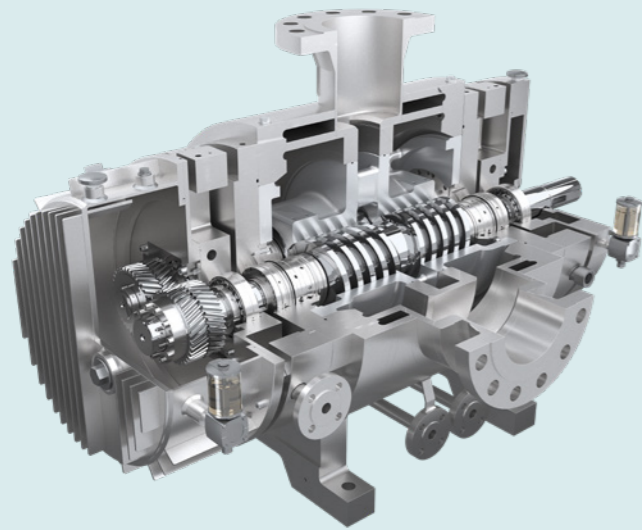

Leistritz screw pumps of series L4 are twin screw double volute, self-priming positive displacement pumps for low, medium and high pressure duty, suitable for transport of abrasive/non abrasive, corrosive/non corrosive, lubricating/non lubricating, high or low viscous fluids.

In the oil & gas industry it is used as pipeline start-up, unloading, tank cleaning, stripping, transfer, booster, circulating, blending and export pump for all kinds of fluids, e.g. multiphase liquids, crude oils, produced water, crude oil/water emulsions, fuel oils, bitumen, tar, asphalt, grease, residues, paraffin, molten sulphur, kerosene, slops, drains and many more.

OPERATING CONDITIONS

	Flow rate max.	Differential pressure max.	Viscosity max.	Temperature max.
L4NG	5,000 m ³ /h 22,000 GPM	16 bar 222 psi	150,000 cSt	350°C 662°F
L4MG	3,900 m ³ /h 17,160 GPM	40 bar 580 psi	150,000 cSt	350°C 662°F
L4HG	2,000 m ³ /h 8,800 GPM	150 bar 2,175 psi	150,000 cSt	350°C 662°F

USER ADVANTAGES

- Rotors (screws and shafts) made out of a single piece of bar stock
 - Limited shaft deflection
 - Low bearing loads
- Maximum allowable rotor deflection limited to 50% of radial clearance between rotor housing and rotor
 - highest process safety
- Gear designs with helical gear teeth
 - Reduced noise level
 - Easy maintenance
- Interchangeable liner → easy maintenance, low costs
 - Special rotor design available
 - Minimized pulsation
 - Optimized NPSHr
 - Low axial flow velocity → excellent priming
 - Axially balanced rotors → no axial forces to bearings
 - Suitable for dry running → maximized process safety

MODULAR

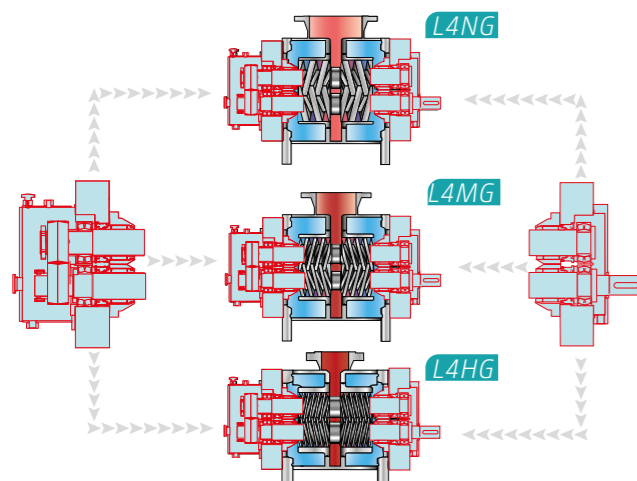

Instead of individual designs, all pumps are designed and manufactured as a modular system. While pump casings, liners and screws are still adapted to the particular operating conditions, bearing covers, bearings, timing gears and the seal components are interchangeable among pumps of different sizes.

L4 COMPACT



The new compact screw pump design for the oil & gas industry!

With focus on tank farm applications such as transfer, stripping, loading and unloading pumps. Further applications: Up- and midstream, ship-building and other offshore technology, chemical and petrochemical industry.

Developed for low capital expenditure (CAPEX) combined with highest efficiency and reliability for optimized operational expenditure (OPEX)

L4NC OPERATING CONDITIONS

Viscosity max.	10,000 cSt
Temperature max.	100 °C [189 °F]
Flow rate max.	5,000 m ³ /h [22,000 GPM]
Suction pressure max.	5 barg
Differential pressure max.	20 bar [290 psi]
Casing design pressure max.	25 bar [362 psi]
Speed max.	3,600 1/min

USER ADVANTAGES

- Pump casing:
 - Economic and slim design for reduced weight
 - Cast steel (1.0619) with integrated liner
 - ANSI & DIN flanges possible
- Spindles:
 - Single bar stock for maximum stiffness
 - Case-hardened steel (1.7139), nitrided for max. hardness
 - Side by side arrangement for excellent lubrication capabilities of spindle, bearings and seals
 - Smooth running with reduced bearing load
- Timing gears:
 - External double helical gear for efficient power transmission
- Mechanical seal:
 - Single acting seals
 - Component or cartridge design (API conform) possible
 - API Plan 02/11 and oil quench possible
- Bearings:
 - Self-aligning roller bearings on DE and NDE side
 - Oil lubricated as an API 676 demand and better lubrication of the shaft seals
 - External lube oil cooler and systems for special applications possible

L2NG

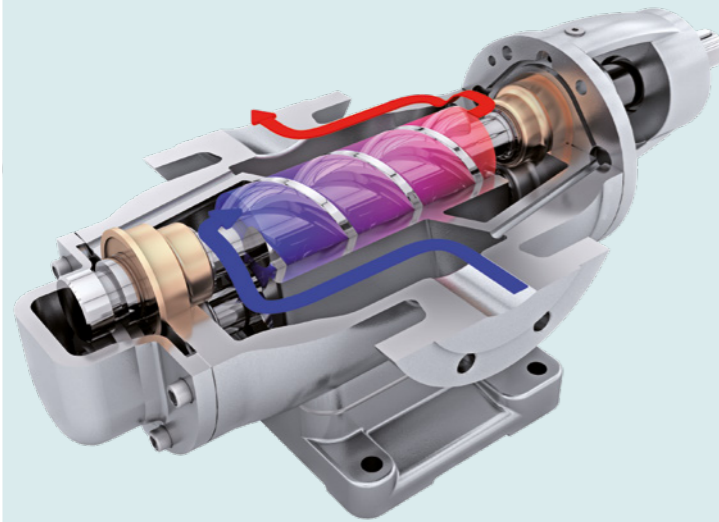

Leistriz screw pumps of the L2NG/NT series are twin screw single volute, self-priming positive displacement pumps for low pressure duty, suitable for transport of slightly abrasive and corrosive, high or low viscous fluids with poor or good lubricity.

In the oil & gas industry it is used as unloading, stripping, circulating, transfer, blending or export pump for fluids with poor and good lubricity, clean or slightly abrasive/corrosive fluids, low and highly viscous fluids, e.g. lube oils, crude oils, fuel oils, bitumen, tar, asphalt, grease, residues, paraffin. It is also used as water turbine in fire-fighting systems.

OPERATING CONDITIONS

Flow rate max.	900 m ³ /h [3,960 GPM]
Differential pressure max.	16 bar [232 psi]
Viscosity max.	100,000 cSt
Pumping temperature max.	280°C [536°F]

USER ADVANTAGES

- High efficiency → low operating costs
- Axially balanced rotors → no axial forces to bearings
- Low axial flow velocity → excellent priming
- Only one shaft seal → easy maintenance, low costs
- Resistant against aeration → low noise, minimized vibration
- Availability of sealless design by magnetic drive
- Semi submersible pump design available

L3MG

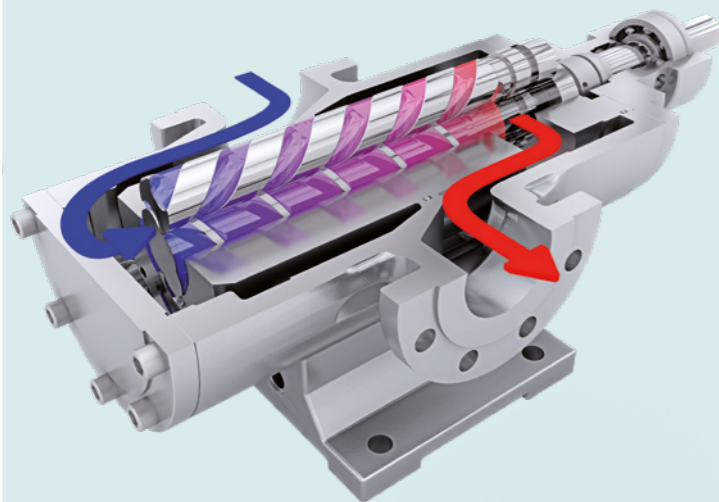

Leistriz screw pumps of the L3MG series are triple screw single volute, self-priming positive displacement pumps for medium pressure duty, suitable for transport of non abrasive, lubricating fluids.

In the oil & gas industry it is used as transfer, circulating, blending or export pump for all kind of clean, lubricating, low/high viscous fluids, e.g. lube oils, crude oils, fuel oils, bitumen, grease, paraffin. Furthermore it is used as foam injection pump in fire-fighting systems.

OPERATING CONDITIONS

Flow rate max.	300 m ³ /h [1,320 GPM]
Differential pressure max.	80 bar [1,160 psi]
Viscosity max.	10,000 cSt
Pumping temperature max.	280°C [536°F]

USER ADVANTAGES

- High efficiency → low operating costs
- Interchangeable casing insert (mg) → easy maintenance
- Axially balanced rotors → no axial forces to bearings
- Only one shaft seal → easy maintenance, low costs
- Availability of sealless design by magnetic drive
- Semi submersible pump design available
- Resistant against aeration → low noise, minimized vibration
- Simple design → reasonable price



DEDICATED SERVICE TEAM

Your satisfaction is the focus of our work.
Each day we want to advise and actively support you.

An after-sales service that can be reached at any time and the immediate global availability of service technicians and spare parts are essential in the modern era. Thus, our service personnel are highly qualified and motivated in order to be able to provide technical support beyond the product itself.

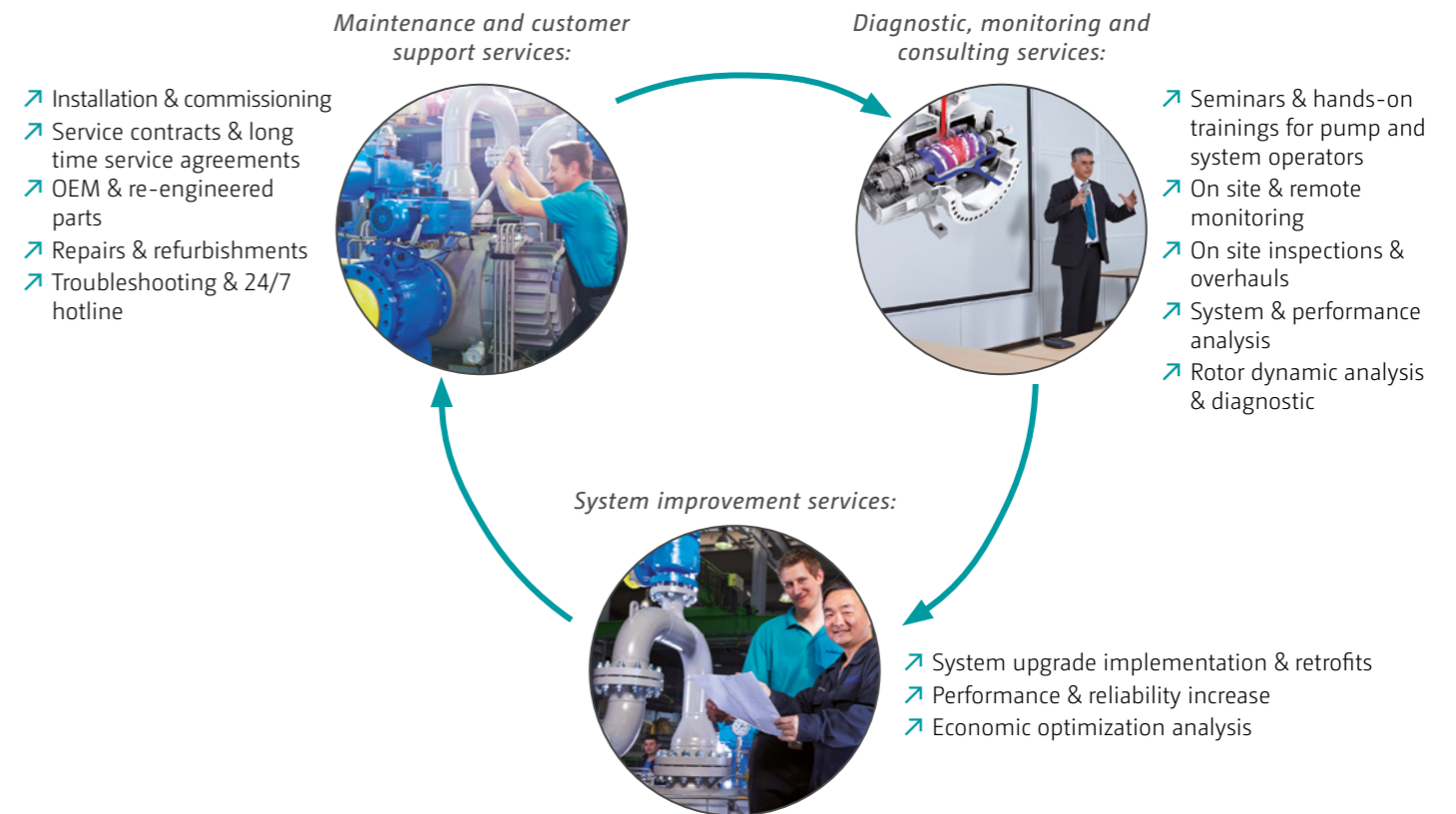

» The Leistriz 24/7 service hotline provides you with advice and assistance in the event of an emergency: +49 911 4306-690.«

Our Service sites:

- Leistriz Italia srl., Milan
- Leistriz Advanced Technologies Corp., Allendale
- Leistriz Machinery (Taicang), Co.,Ltd., Taicang
- Leistriz SEA, Pte. Ltd., Singapore
- Leistriz Middle East FZE, Sharjah, UAE
- Leistriz India Pte. Ltd., Chennai



MANUFACTURING KNOW-HOW

»Leistriz pumps are manufactured with expertise and passion.«





Rising demands on pump manufacturers regarding wear protection, service life or flow rate require the use of state-of-the-art machine technology and process chains that are ideally coordinated with one another. These are the prerequisites to facilitate the high-quality manufacturing of pump components.

To accomplish this high standard, we produce the screws and housings, i.e. the core elements of the

Leistriz pumps, ourselves in Germany - under the aspect of the ultimate precision and with a high level of production knowledge vertical integration.

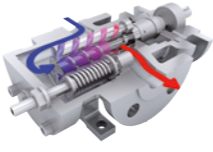
This is particularly due to the symbiosis of the various products of the Leistriz Group in the form of superior materials know-how and in-house metal processing technologies, such as whirling. In addition to our numerous machines, it is particularly our team that convinces our customers with its well-founded expertise and extensive manufacturing know-how.

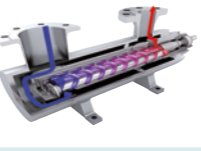
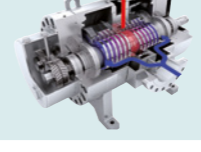
PUMP RANGE

SERIES	USE FOR	PUMP TYPE	PERFORMANCE DATA			
			Flow rate	Pressure	Viscosity	Temperature
L2N	Low pressure duty, suitable for transport of slightly abrasive and corrosive, high or low viscous fluids with poor or good lubricity.		900 m³/h 3,960 GPM	16 bar 232 psi	100,000 cSt	280°C 536°F
L3N	Low pressure duty, suitable for transport of non-abrasive lubricating fluids.		700 m³/h 3,100 GPM	16 bar 232 psi	15,000 cSt	180°C 356°F
L3M	Medium pressure duty, suitable for transport of non-abrasive lubricating fluids.		300 m³/h 1,320 GPM	80 bar 1,160 psi	10,000 cSt	280°C 536°F
L3H L3U	High and ultra high pressure duty, suitable for transport of non-abrasive, slightly abrasive and corrosive, high or low viscous fluids with poor or good lubricity.		200 m³/h 880 GPM	280 bar 4,060 psi	10,000 cSt	280°C 536°F
L4N L4M L4H	Low, medium and high pressure duty, suitable for transport of abrasive/non-abrasive, corrosive/non-corrosive, lubricating/non-lubricating, high or low viscous fluids.		5,000 m³/h 22,000 GPM	150 bar 2,175 psi	150,000 cSt	350°C 662°F
L5N	Low pressure duty, suitable for transport of slightly abrasive and corrosive, high or low viscous fluids with poor or good lubricity.		1,700 m³/h 7,500 GPM	10 bar 145 psi	100,000 cSt	280°C 536°F

This list offers a general overview of the standard pump range by Leistriz. Various options and systems are individually configured according to customer requirements and tested on our test bench (drive power up to 4 MW) in Nuremberg.

LEISTRITZ PUMP TECHNOLOGY - AT YOUR SERVICE, GLOBALLY.

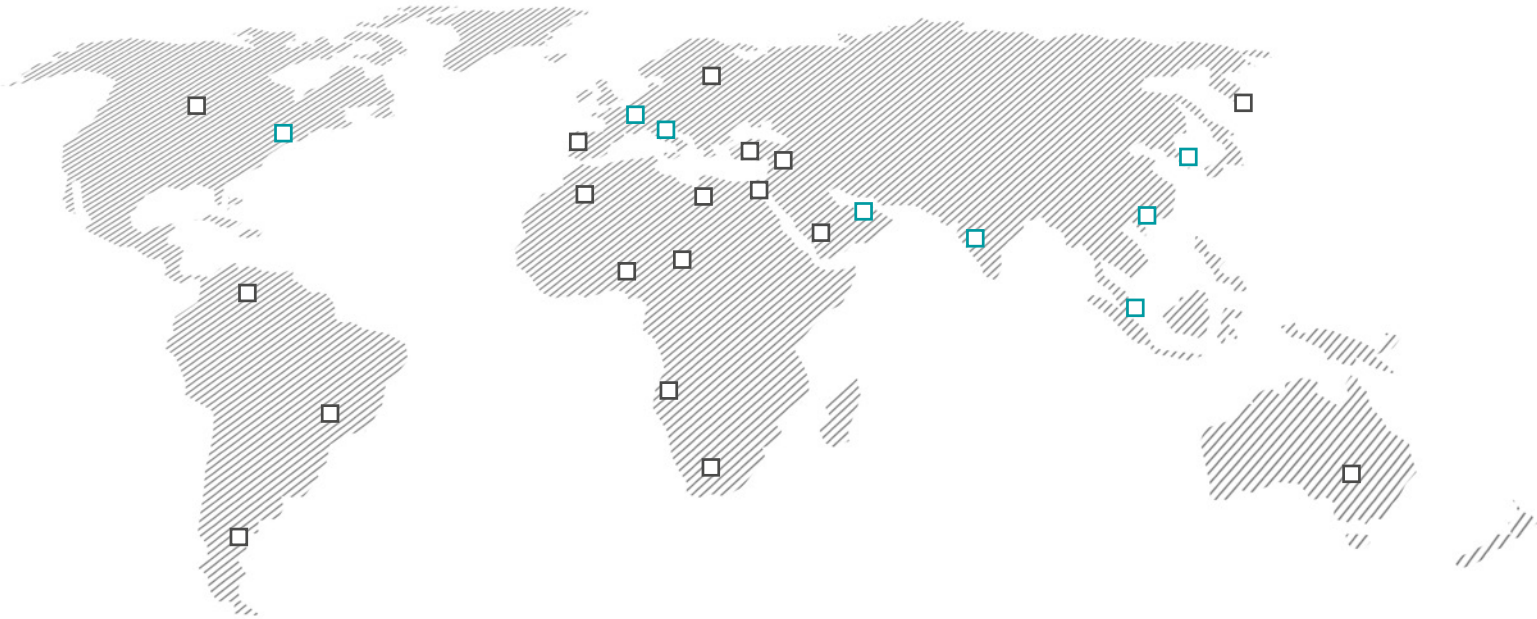

HEADQUARTERS

Leistritz Pumpen GmbH
Markgrafenstraße 36-39
90459 Nuremberg
Germany

P +49 911 4306-9650
E pumps@leistritz.com
pumps.leistritz.com



SUBSIDIARIES

Leistritz Italia srl
Milano, Italy

Leistritz Advanced Technologies Corp.
Allendale, NJ, USA

Leistritz Machinery (Taicang) Co., Ltd.
Jiangsu & Shanghai, China

Leistritz Korea Co. Ltd.
Seoul, Korea

Leistritz India Pte Ltd.
Chennai, India

Leistritz Middle East (FZE)
Sharjah, United Arab Emirates

Distributor network
for regional and local service